

Operating Instructions

e-STATION 301DX-II

Microprocessor controlled high-performance rapid charger/discharger
USB PC link and temperature sensor

Charge current up to 5A, discharge current up to 1A, 1 to 6 series of Lilo/LiPo/LiFe, 1 to 15 cells of NiCd/NiMH, 2 to 20V of Lead-acid (Pb)



BANTAM

* We reserve the right to commit modifications.
* Copyright reserved

Thank you for purchasing the e-STATION 301DX-II charger. You get a rapid charger/discharger which is computerized with a high performance microprocessor and specialized operating software. It can maintain your battery at its best condition and also control them safely. Please read this operating instructions completely and attentively as it contains a wide variety of specific programming and safety information.

You need to keep this manual in a safe place, and be sure to pass it on to the new owner if you ever dispose of this device.

● Special features

- Operating software

Every operating program in the unit is controlled with mutual links and communications to prevent every possible error, so it introduces the maximum safety, such as input voltage warning, reverse polarity protection and Lithium cell-count input error warning.

- Accept various types of Lithium battery

This charger can accept three types of Lithium batteries - Lilo, LiPo and LiFe. They have different characteristics by their chemistry. You can select any one of them that you are going to process before the job. For their specifications, refer 'Warnings and safety notes' section.

- Maximum safety

Capacity limit : The charging capacity always calculated by multiple of the charging current and time. If the charging capacity exceeds the limit the process will be terminated automatically when you set the maximum value.

Temperature limit(*) : The temperature of the battery on charging will rise by its internal chemical reaction. If you set the limit of temperature the process will be expired forcibly when the limit has been reached.

Processing time limit : You can also restrain the maximum processing time to prevent from any possible defect.

Input power monitor : To protect the car battery using as input power from being damaged, its voltage always being monitored under operation. If it drops below the lower limit, the process will be ended automatically.

- Cyclic charging/discharging

Perform 1 to 5 cycles of charge>discharge or discharge>charge continually for battery refreshing and balancing.

- PC based analysis using USB communication(**)

For technical expert, 301DX-II offers PC based program can analysis the characteristic of the battery by USB port. It shows a graph of voltage, current, capacity and temperature curves. It also shows the individual voltage of each cell in the Lithium battery pack.

* When using the thermal probe (Part no. EAC110)

** Separately purchased program kit (EAC300, CD plus USB link cable)

● Exterior of the unit

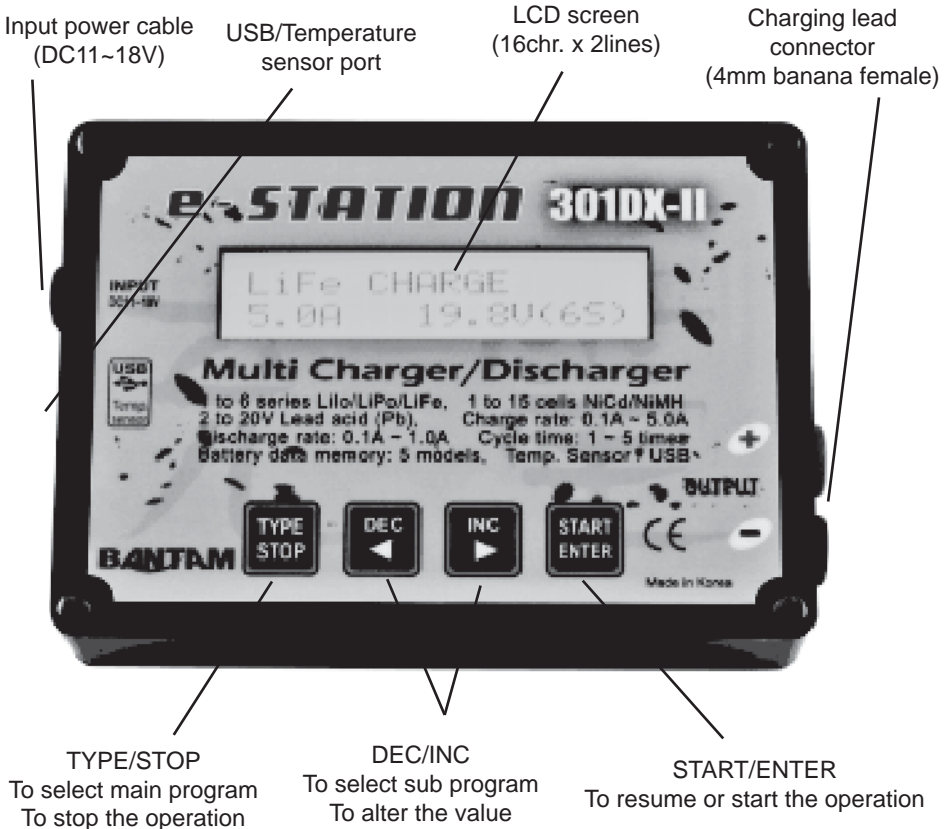

● Warnings and safety notes

- Never leave the charge unsupervised when it is connected to its power supply. If any malfunction is observed immediately terminate the process and refer to the operation manual.
- Keep away the unit from dust, damp, rain, heat direct sunshine and vibration. Do not drop it.
- The circuit of the unit is designed to be powered by a 12V DC only.
- This unit and the battery to charge or discharge should be set up on a head-resistant, non-inflammable and non-conductive surface. Never place them on a car seat, carpet or similar. Keep all the inflammable volatile materials well away from operating area.
- Be sure to understand the information of the battery to be charged or discharged accurately. If the program is set up incorrectly the battery can severely be damaged. Especially Lithium battery can cause a fire or an explosion by over-charging.

NiCd/NiMH voltage level: 1.2V/cell
allowable fast charge current: 1C ~ 2C depends on the performance of cell
discharge voltage cut off level: 0.9V/cell(NiCd), 1.0V/cell(NiMH)

Lilo voltage level: 3.6V/cell
max. charge voltage: 4.1V/cell
allowable fast charge current: 1C or less
min. discharge voltage cut off level: 3.0V/cell or higher

LiPo voltage level: 3.7V/cell
max. charge voltage: 4.2V/cell
allowable fast charge current: 1C or less
discharge voltage cut off level: 3.0V/cell or higher

LiFe voltage level: 3.3V/cell
max. charge voltage: 3.6V/cell
allowable fast charge current: 4C or less (e.g. A123M1)
discharge voltage cut off level: 2.0V/cell or higher

Pb voltage level: 2.0V/cell
(Lead-acid) max. charge voltage: 2.45V/cell
allowable fast charge current: 0.4C or less
discharge voltage cut off level: 1.5V/cell or higher

- To avoid short-circuits between the charge lead, always connect the charge cable to the unit first and only then to the battery to be charged or discharged. Reverse the sequence when disconnecting.
- Do not connect more than one battery pack to the charge lead at any one time.
- Do not attempt to charge or discharge the following types of battery.
 - Battery pack, which consists of different types of cell (including different manufacturers).
 - Battery, which is already fully charged or just slightly discharged.
 - Non-rechargeable batteries (Explosion hazard).
 - Batteries that require a different charge technique from NiCd, NiMH, Lilo, LiPo, LiFe or Pb.
 - Faulty or damaged battery.
 - Battery fitted with an integral charge circuit or a protection circuit.
 - Batteries installed in a device, or which are electrically linked to other components.
 - Batteries that are not expressly stated by the manufacturer to be suitable for the currents the charger delivers during the charge process.

- Please bear in mind of checking the following point before charge operation.
 - Did you select the appropriate program, which are suitable for the type of battery?
 - Did you set up adequate current for charging or discharging?
 - Lithium battery pack can be composed with parallel and series circuits mixed. You have to check the composition of the battery pack carefully before charging.
 - Are all connections firm and safe, or is there an intermittent contact at any point in the circuit?

- **Charging**

A specific quantity of electrical energy is fed into the battery during charge process. The charge quantity is calculated by multiplying charge current by charge time. The maximum permissible charge current varies according to the battery type or its performance, and can be found in the information provided by the battery manufacturer. It is only allowed to charge batteries at rates higher than the standard charge current if they are expressly stated to be capable of quick-charge.

- Connect the battery to charge to output terminal of the charger using suitable charge lead. They are red, positive (+) and black, negative (-). Since the charger cannot detect the difference between the internal resistance of the battery pack, cable resistance and connector transfer resistance, the first requirement if the charger to work properly is that the charge lead should be of adequate conductor cross-section. And also high-quality connectors (normally gold-contact type) must be fitted to both ends.

- Refer to the information provided by the battery manufacturer regarding charging methods, and verify the recommended charge current and charge time. Especially for Lithium batteries, you have to follow the charge instruction provided by the manufacturer strictly.

- Do not attempt to disassemble the battery pack arbitrarily.

- You have to pay attention to verify the capacity and the voltage of the Lithium battery pack. It may be composed of parallel and series connection mixed. In parallel link the capacity of the battery pack is multiplied by the number of cells but the voltage remains same. That kind of voltage imbalance causes a fire or explosion during charge process. We recommend you compose the Lithium battery pack in series only.

- **Discharge**

The typical purpose of discharge is to determine the residual capacity of the battery, or to lower the voltage of battery to a defined level. When you discharge the battery you also have to pay attention on the process same as charging. To avoid the battery becoming deep-discharged, set the final discharge voltage correctly. Lithium batteries should not be deep-discharged to lower than the minimum voltage, as this leads to a rapid loss of capacity or a total failure. Generally, you do not need to discharge Lithium battery voluntarily.

- Some rechargeable batteries are said to have a memory effect. If they are partly used and recharged before the whole charge is drawn out, they 'remember' this and next time will only use that part of their capacity. This is a 'memory effect'. NiCd and NiMH batteries are said to suffer from memory effect. They prefer complete cycles; fully charge then use until empty, do not recharge before storage - allow them to self-discharge during storage. NiMH batteries have less memory effect than NiCd.

- The Lithium battery prefers a partial rather than a full discharge. Frequent full discharges should be avoided if possible. Instead, charge the battery more often or use a larger battery.

- The brand-new NiCd battery pack is partially useful with its capacity until it has been subjected to 10 or more charge cycles in any case. The cyclic process of charge and discharge will lead to optimize the capacity of battery pack.

Those warnings and safety notes are particularly important. Please follow the instructions for a maximum safety; otherwise the charger and the battery can be damaged violently. And also it can cause a fire to injure a human body or to lose the property.

Program flow chart

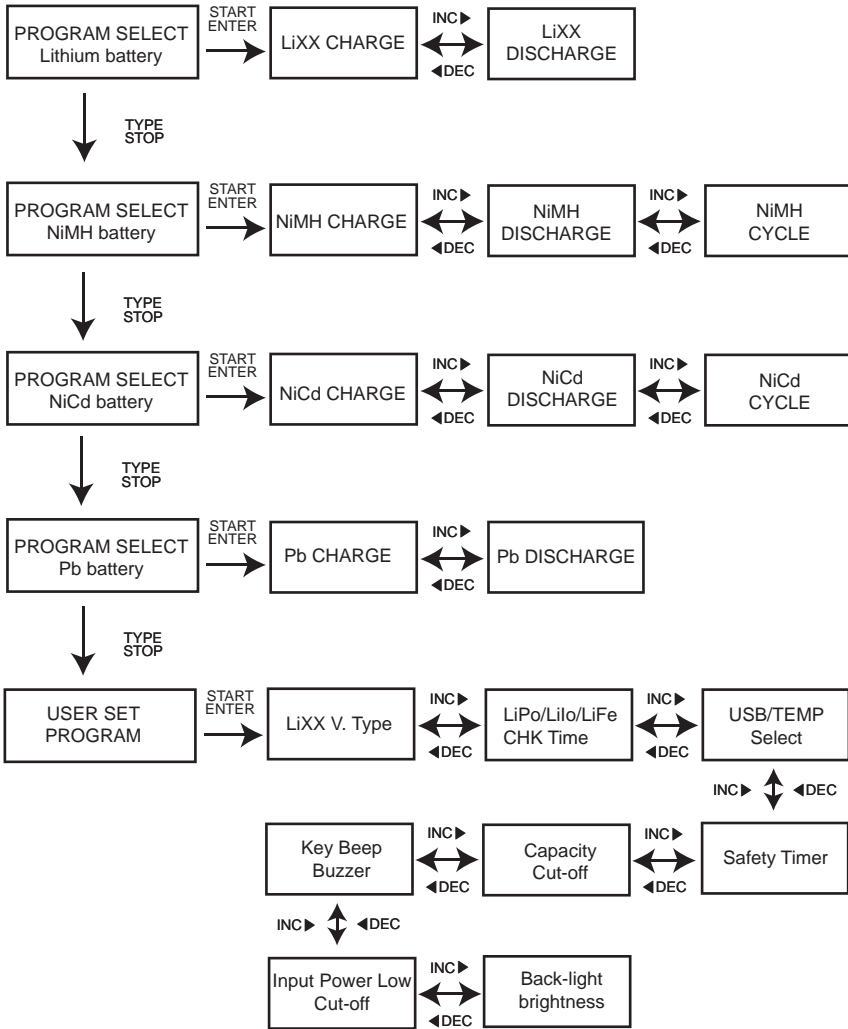

● Initial parameter set up (Users set program)

301DX-II will be operated with the default value of the essential user settings when it is connected to the input power source for the first time. The screen displays the following information in sequence and the user can change the value of parameter on each screen.

When you are willing to alter the parameter value in the program, press START_ENTER key to make it blink then change the value with $\langle \text{DEC} \rangle$ or $\langle \text{INC} \rangle$ key. The value will be stored by pressing START_ENTER key once.

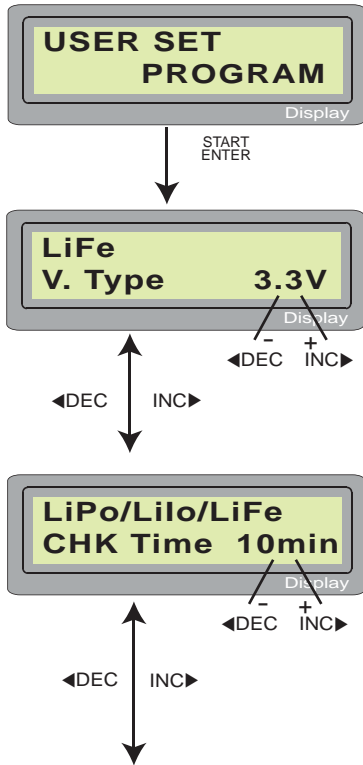

This informs you of its designation

The screen displays the nominal voltage of Lithium battery. There are three kinds of Lithium battery; LiFe(3.3V), Lilo(3.6V) or LiPo(3.7V). This is very important so you have to check the battery carefully and set it up correctly. If it is different from correct value the battery can explode during charge process.

The charger recognizes the cell count of Lithium battery automatically at the beginning of charge or discharge process to avoid from erroneous setting by user. But deeply discharged battery can be perceived incorrectly. To prevent the error, you can set the time term to verify the cell count by the processor. Normally, 10 minutes are enough to perceive the cell count correctly. For the battery of larger capacity, you may extend the time term. But if you set the time term too long for the battery of smaller capacity, the charge or discharge process can be finished within the time term with the erroneous cell count. This may cause the fatal result. If the processor recognizes the cell count incorrectly at the beginning of charge or discharge process, you may extend the time. Otherwise, you had better use with the default value.

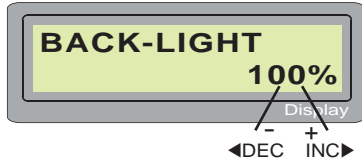
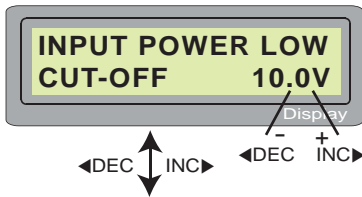
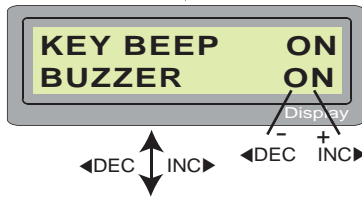
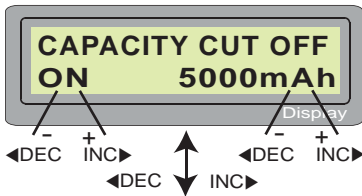
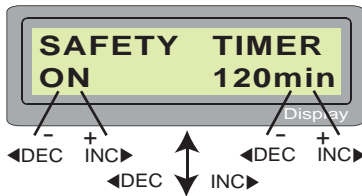
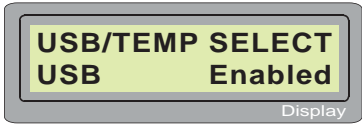
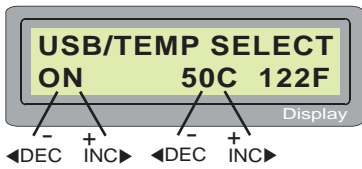

You can select the function of 3-pin port at left side of the unit. It can be used temperature sensor port or USB port. If the port is assigned as a temp. port, an optional temperature probe contacting the surface of battery can be used. When it is selected as an USB port, you can link the charger to your PC via an optional USB cable. This can utilize the optional software that can show you the charging process at PC. You can set the maximum temperature at which the charger should allow battery to reach during charge. Once a battery reaches this temperature during charge, the process will be terminated to protect the battery.

When you start a charge process, the integral safety timer automatically starts running at the same time. This is programmed to prevent overcharge the battery if it proves to be faulty, or if the termination circuit cannot detect the battery full. The value for the safety timer should be generous enough to allow a full charge of the battery.

This program sets the maximum charge capacity that will be supplied to the battery during charge. If the delta-peak voltage is not detected nor the safety timer expired by any reason, this feature will automatically stop the process at the selected capacity value.

The beep sounds at every time pressing the buttons to confirm your action. The beep or melody sounded at various times during operation to alert different mode changes. These audible sounds can be on or off.

This program monitors the voltage of input battery. If the voltage drops below the value you set the operation forcibly terminated to protect the input battery.

You can adjust the brightness of LCD screen at the charger.

● Lithium battery (Lilo/LiPo/LiFe) program

These programs are only suitable for charging and discharging Lithium batteries with a nominal voltage of 3.3V, 3.6V and 3.7V per cell. These batteries need to adopt different charge technique is termed constant voltage(CV) and constant current(CC) method. The charge current varies according to the battery capacity and performance. The final voltage of charge process is also very important; it should be precisely matched with the charged voltage of the battery. They are 4.2V for LiPo, 4.1V for Lilo, and 3.6V for LiFe. The charge current and nominal voltage as for cell count set on the charge program must always be correct for the battery to be charged.

When you are willing to alter the parameter value in the program, press **START ENTER** key to make it blink then change the value with **INC** or **DEC** key. The value will be stored by pressing **START ENTER** key once.

Charging Lithium battery

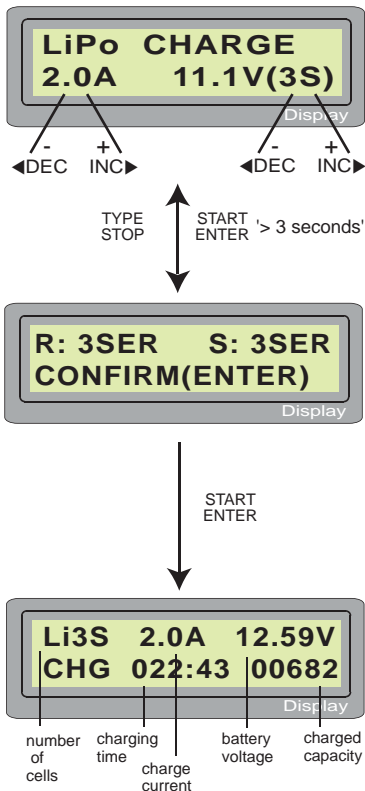

The left side of the first line shows the type of battery you select at the users setting. The value on the left side of second line sets a charge current and the value on the right side of second line sets the voltage of the battery pack.

After setting the current and voltage press **START ENTER** key for more than 3 seconds to start the process. (Charge current: 0.1~5.0A, Voltage: 1~6 series)

This shows the number of cells you set up and the processor detects. 'R:' shows the number of cells found by the charger and 'S:' is the number of cells selected by you at the previous screen. If both numbers are identical you can start charging by press **START ENTER** button. If not, press **TYPE STOP** button to go back to previous screen. Then carefully check the number of cells of the battery pack to charge again.

The screen shows the present situation during charge process.

To stop charging press **TYPE STOP** key once.

Discharging Lithium battery

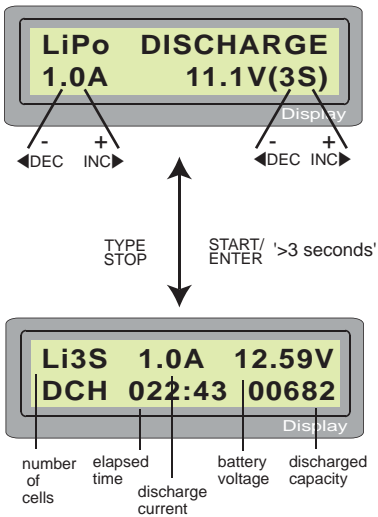

The value of discharge current on the left side of screen may not exceed 1C for a maximum safety and the final voltage on the right should not be under the voltage level that is recommended by the battery manufacturer to avoid deep discharging.

To start to discharge press **START/ENTER** key for more than 3 seconds.

(Discharge current: 0.1~1.0A)

This shows the present state of discharge. To stop discharging press **TYPE STOP** key once.

● NiMH/NiCd battery program

These programs are for charging or discharging NiMH (Nickel-Metal-Hydride) or NiCd (Nickel-Cadmium) battery commonly used for R/C model applications. To alter the value at the display, press **START ENTER** key to make it blink then change the value using **INC▶** or **◀DEC** key. The value will be stored by pressing **START ENTER** key once.

To start the process, press **START ENTER** button for more than 3 seconds.

Charging NiCd/NiMH battery

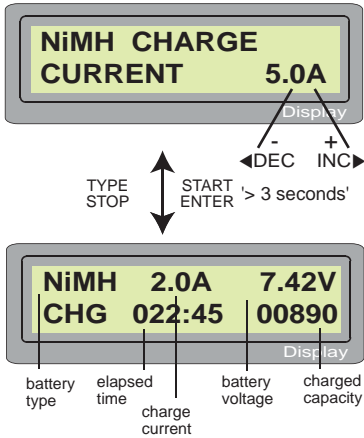

This program simply charges the battery using the current you set.

The screen displays the current state of charging. To stop the process, press **TYPE STOP** key once. The audible sound indicates you the end of process.

Discharging NiCd/NiMH battery

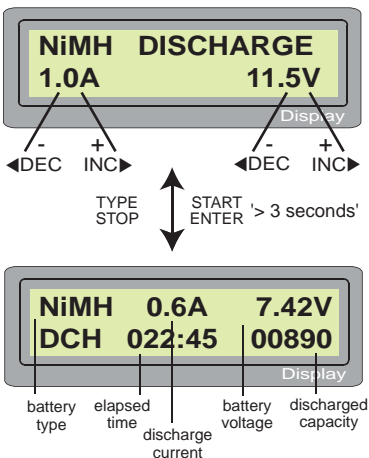

Set discharge current on the left and final voltage on the right. The discharge current ranges from 0.1 to 1.0A and the final voltage ranges from 0.1 to 20.0V). To start the process, press **START ENTER** key for more than 3 seconds.

The screen displays the current state of discharge. You can alter the discharge current by pressing **START ENTER** key during the process. Once you change the current value, store it by pressing **START ENTER** button again.

To stop discharging press **TYPE STOP** key once. The audible sound indicates you at the end of process.

Charge-to-discharge & discharge-to-charge cycle NiMH/NiCd battery

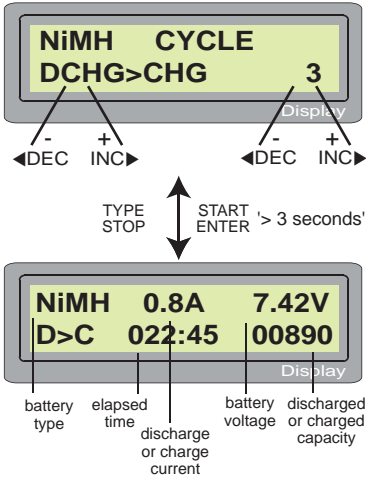

Set the sequence on the left and the number of cycle on the right. You can use this function for balancing, refreshing and break-in the battery. The cycling number ranges from 1 to 5.

To stop the process, press TYPE STOP key once. You can change the discharge or charge current by pressing START ENTER key once during the process. The audible sound indicates you the end of process.

At the end of the process, you can see charged or discharged electric capacities of the battery at each cyclic process.

By pressing INC▶ or ◀DEC button, the screen shows the result of each cycle in order.

● Pb (lead-sulphuric acid) battery program

This is programmed for charging Pb (lead-acid) battery with nominal voltage from 2 to 20V. Pb batteries are totally different from NiCd or NiMH batteries. They can only deliver relatively lower current compare to their capacity, and similar restrictions definitely apply to charge. So the optimal charge current will be 1/10 of the capacity. Pb batteries must not be charged rapidly. Always follow the instruction is supplied by the manufacturer of battery. When you are willing to alter the parameter value in the program, press **START ENTER** key to make it blink then change the value with **INC** or **DEC** key. The value will be stored by pressing **START ENTER** key once.

Charging Pb battery

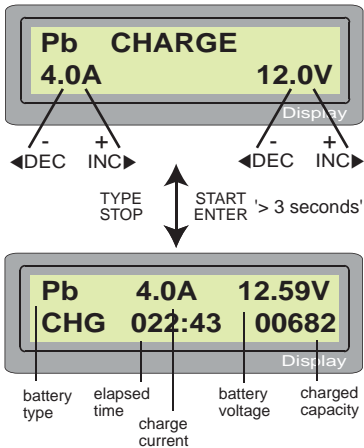

Set up the charge current on the left and the nominal voltage of the battery on the right. The charge current ranges from 0.1 to 5.0A and the voltage should be matched with the battery being charged.

Start the charge process by pressing **START ENTER** key for more than 3 seconds.

The screen displays the state of charging process. To stop charging forcibly, press **TYPE STOP** key once. The audible sound indicates you at the end of process.

Discharging Pb battery

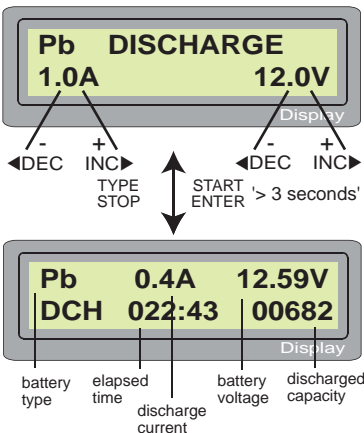

Set discharge current on the left and final voltage on the right. The discharge current ranges from 0.1 to 1.0A.

To start the process, press **START ENTER** key for more than 3 seconds.

The screen displays the current state of discharge. You can alter the discharge current by pressing **START ENTER** key during the process. Once you change the current value, store it by pressing **START ENTER** button again.

To stop discharging press **TYPE STOP** key once. The audible sound indicates you at the end of process.

● Various information during the process

You can inquire various information on LCD screen during charging or discharging process. When you press **INC▶** button the charger shows the establishment of user settings. And also you can monitor the voltage of individual cell by pressing **INC▶** button when the individual connection cable is linked to the Lithium battery being processed.

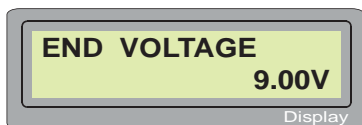

The final voltage will be reached at the end of process.

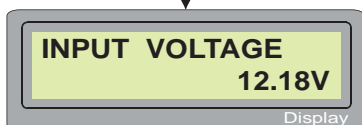

The present voltage of input DC power.

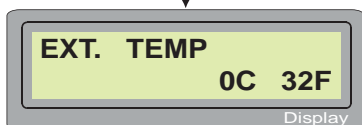

The internal temperature of the charger and the temperature of battery being charged. (The external temperature only will be displayed when using the thermal probe, or it will be zero.)

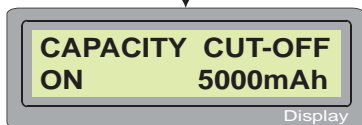
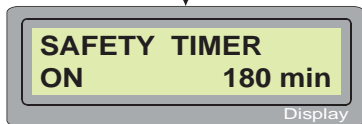
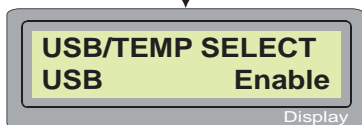

● Warning and error messages

301DX-II incorporates a various functions of protective and monitoring the system to verify functions and the state of its electronics. In any case of occurring error, the screen displays the cause of error that is self-explanatory with audible sound.

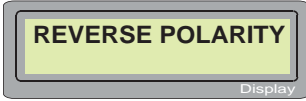

The output is connected to a battery with incorrect

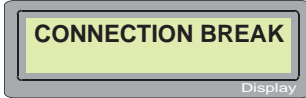

This will be displayed in case of detecting an interruption of the connection between battery and output or voluntarily disconnecting the charge lead during the operation of charge or discharge on output.



There was a short-circuit at OUTPUT. Please check the charging leads.



The voltage of input power drops below the limit.

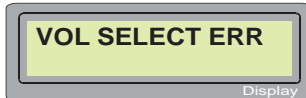

The voltage of Lithium battery pack was selected incorrectly. Verify the voltage of battery pack carefully.



There happens the malfunction at the charger circuit by any reason. The charger should be repaired at the factory.

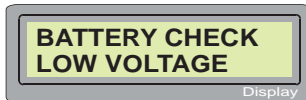

The processor detects the voltage is lower than you set at Lithium program. Please check the cell count of the battery pack.

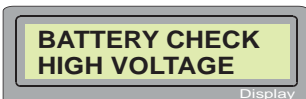

The processor detects the voltage is higher than you set at Lithium program. Please check the cell count of the battery pack.

● Glossary of terms

Amps(A): The unit of measure for charge or discharge electric current. The program of the charger will show most of the current in amps(A) at its LCD screen.

Milli-amps(mA): The electric current, being amps(A) multiplied by 1000 and noted as 'mA'. So 2.0A is the same as 2000mA (2.0x1000). Or, to convert mA to amps, divide the mA number by 1000. So 200mA is the same as 0.2A. If a current value is below 1.0A, the LCD screen of the charger will still show the current in amps, not milli-amps. For example, a current of 600mA will be displayed as 0.6A, and a current of 100mA will actually be shown as 0.1A.

Capacity, milli-amp hours (mAh), and amp-hours (Ah): Charge energy stored by a battery is called capacity, which is defined as how much current a battery can supply constantly over one hour of time. Most hobby batteries are rated for capacity in 'mAh' or milliamp hours. A 650mAh battery can deliver 650mA of current for one hour (650mA x 1hr = 650mAh). The batteries of very large capacity, such as lead-acid(Pb) batteries, are usually rated in 'Ah' or amp-hours. A '12V 60Ah' car battery can deliver 60 amps of current for one hour (60A x 1hr = 60Ah).

Nominal voltage(V): The nominal voltage of the battery pack can be determined as follows;

-NiCd or NiMH: multiply the total number of cells in the pack by 1.2. A 8-cell pack will have a nominal voltage of 9.6 volts (8x1.2).

-LiPo: multiply the total number of cells in the pack by 3.7. A 3-cell LiPo wired in series will have a nominal voltage of 11.1 volts (3x3.7).

-Lilo: multiply the total number of cells in the pack by 3.6. A 2-cell Lilo wired in series will have a nominal voltage of 7.2 volts (2x3.6).

-LiFe: multiply the total number of cells in the pack by 3.3. A 4-cell Lilo wired in series will have a nominal voltage of 13.2 volts (4x3.3).

If the nominal voltage of the battery is not printed on the battery's label, consult your battery manufacturer or supplier. Do not guess the rated voltage of battery.

'C'-rating: Capacity is also referred to as the 'C' rating. Some battery suppliers recommend charge and discharge currents based on the battery 'C' rating. A battery's '1C' current is the same number as the battery's rated capacity number, but noted in mA or amps. A 600mAh battery has a 1C current value of 600mA, and a 3C current value of (3 x 600mA) 1800mA or 1.8A. The 1C current value for a 3200mAh battery would be 3200mA (3.2A).

● Maximum circuit power chart

For the voltage of battery is more than 12V, the actual amount of charge current delivered to the battery might automatically be limited, so not to exceed the charger's maximum rated charging power of 50 watts. And also, for the battery having more than 5V, the discharge current delivered to the battery might be limited by the maximum rated discharge power of 5 watts. The actual feeding current will be as follows;

Maximum charge/discharge current at 12V DC input				
	No. of cells	Rated voltage(V)	Charge current(A)	Discharge current(A)
NiCd/NiMH	1	1.2	5.0	1.0
	2	2.4	5.0	1.0
	3	3.6	5.0	1.0
	4	4.8	5.0	1.0
	5	6.0	5.0	0.8
	6	7.2	5.0	0.7
	7	8.4	5.0	0.6
	8	9.6	5.0	0.5
	9	10.8	4.6	0.5
	10	12.0	4.2	0.4
	11	13.2	3.8	0.4
	12	14.4	3.5	0.3
	13	15.6	3.2	0.3
	14	16.8	3.0	0.3
	15	18.0	2.8	0.3
LiPo	1S	3.7	5.0	1.0
	2S	7.4	5.0	0.7
	3S	11.1	4.5	0.5
	4S	14.8	3.4	0.3
	5S	18.5	2.7	0.3
	6S	22.2	2.3	0.2
LiFe	1S	3.3	5.0	1.0
	2S	6.6	5.0	0.8
	3S	9.9	5.0	0.5
	4S	13.2	3.8	0.4
	5S	16.5	3.0	0.3
	6S	19.8	2.5	0.3
Lilo	1S	3.6	5.0	1.0
	2S	7.2	5.0	0.7
	3S	10.8	4.6	0.5
	4S	14.4	3.5	0.3
	5S	18.0	2.8	0.3
	6S	21.6	2.3	0.2
Pb		6.0	5.0	0.8
		8.0	5.0	0.6
		10.0	5.0	0.5
		12.0	4.2	0.4
		14.0	3.6	0.4
		16.0	3.1	0.3
		18.0	2.8	0.3
		20.0	2.5	1.3

● Specifications

Operating voltage range :	11.0 ~ 18.0 Volt
Circuit power:	max. 50Watts (Charging) max. 5 Watts (discharging)
Charge current range :	0.1 ~ 5.0A
Discharge current range :	0.1 ~ 1.0A
NiCd/NiMH battery cell count :	1 ~ 15 cells
Lithium battery cell count :	1 ~ 6 Series
Pb battery voltage :	2 to 20V
Weight :	320 g
Dimensions :	113 X 80 X 28 mm

● Warranty and service

We warrant this product for a period of one year (12 months) from the date of purchase. The guarantee applies only to such material or operational defects, which are present at the time of purchasing the product. During that period, we will repair or replace without service charge any product deemed defective due to those causes. Any repairs carried out under warranty do not extend the original warranty period. You will be required to present proof of purchase (invoice or receipt). The defective unit has to be sent to us by pre-paid delivery; we will pay for return shipping cost. This warranty does not cover the damage due to wear, overloading, incompetent handling or using of incorrect accessories.

BANTAM INC.

#623 Unitech Ville 1141-2
BAEKSEOKDONG ILSANDONGGU
GOYANGSI KYUNGGIDO
KOREA 410-722
Phone: +82 31 904 3939, Fax: +82 31 901 6439
E-mail: bantamtek@bantamtek.com



Electrical equipment marked with the cancelled waste bin symbol must not be discarded in the standard household waste; instead it should be taken to a suitable specialist disposal system.

Date of purchase/delivery :

Dealer :